

International Arrivals Facility (IAF)

Action Briefing

December 8, 2015

Agenda

- Early Schematic Design Concept
- Target Schedule
- Target Budget
- Additional Funding Request

Design-Build Contract

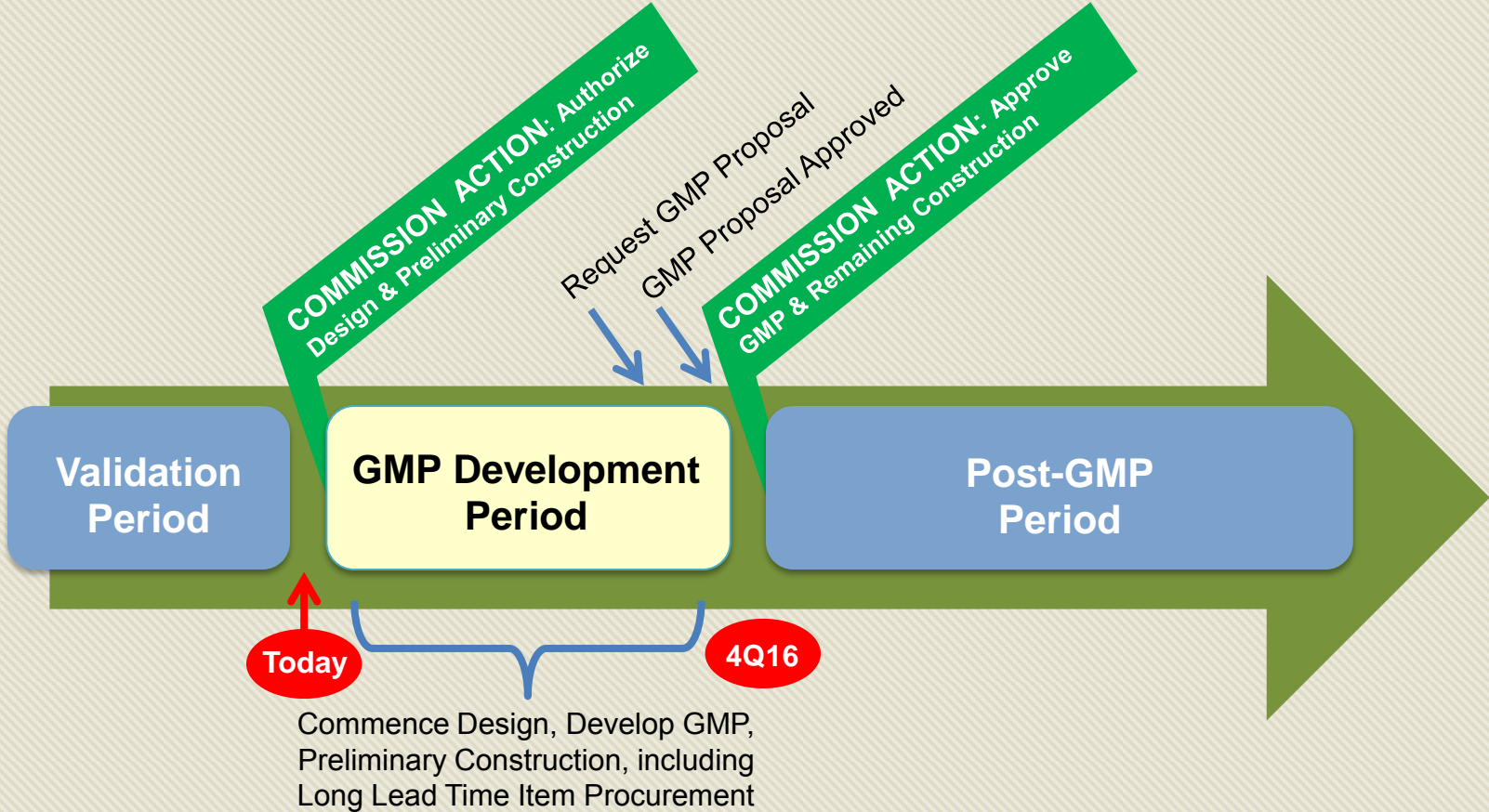

Working towards Guaranteed Maximum Price (GMP)

Second Contract Period

- **GMP Development Period:**
 - Advance design to 60% level (or beyond)
 - Preliminary construction, including the purchase of long lead-time items (e.g., steel, escalators and elevators)
 - Negotiate Guaranteed Maximum Price (GMP) for the work (4Q16)

Advance Design and Develop a Guaranteed Maximum Price (GMP)

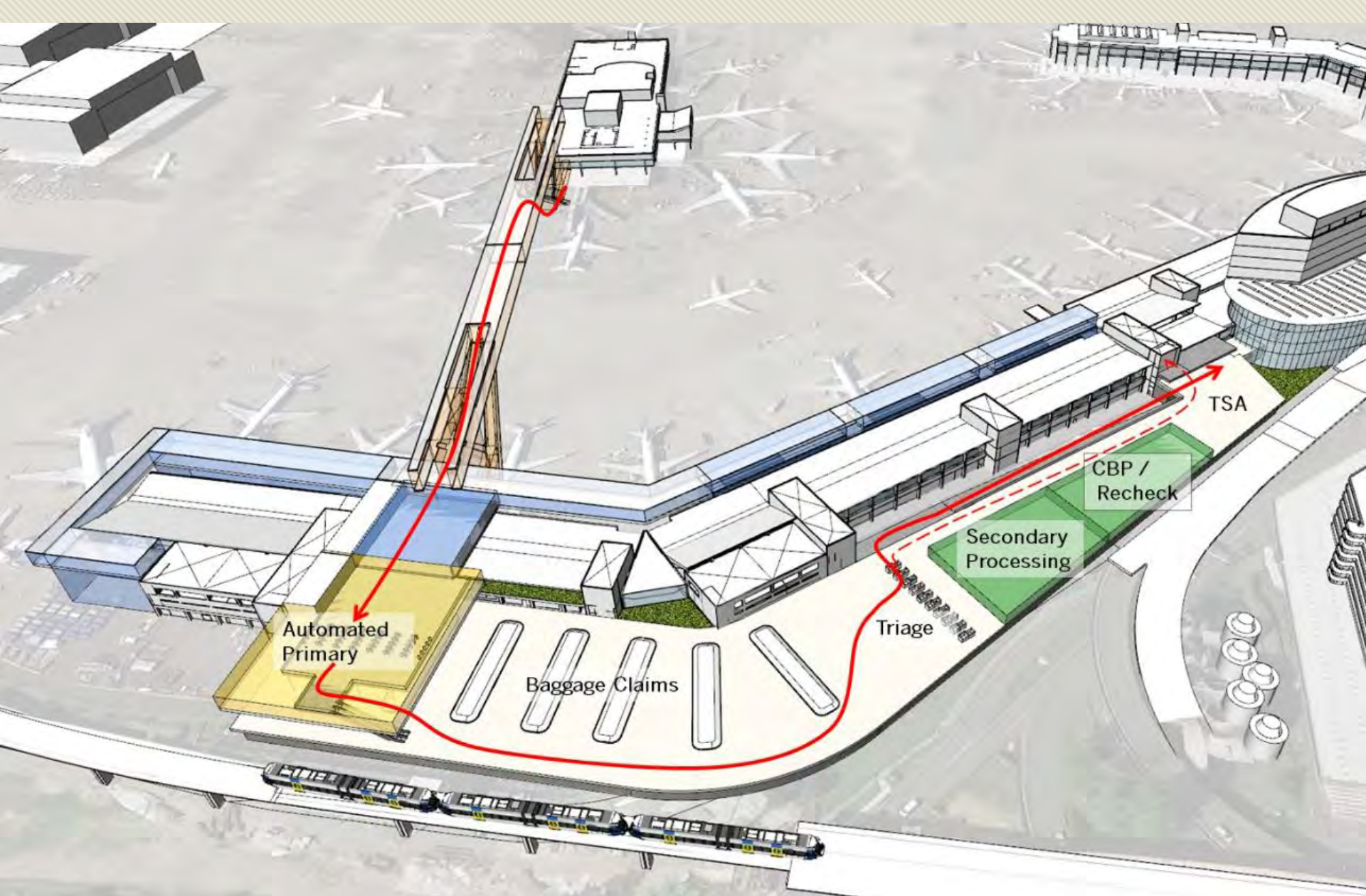

Early Schematic Design Concept Established by Design-Builder

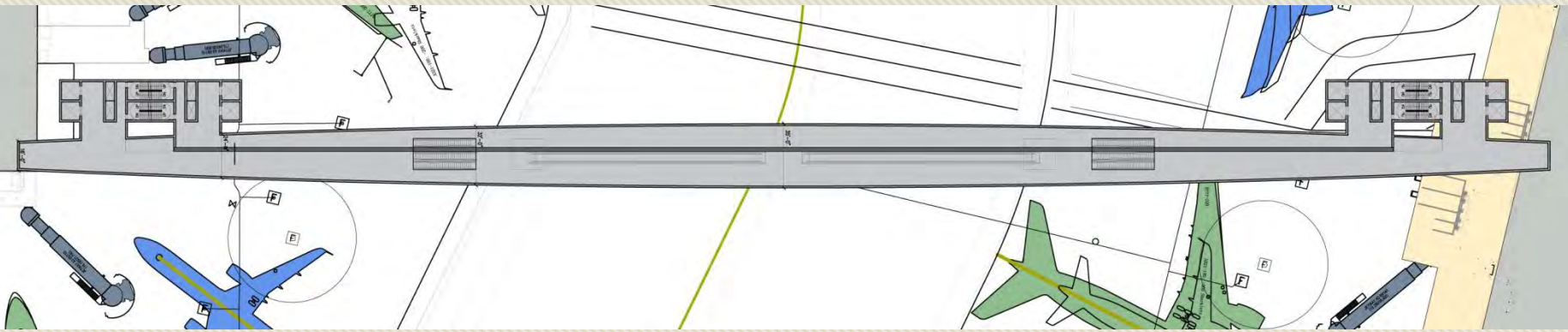
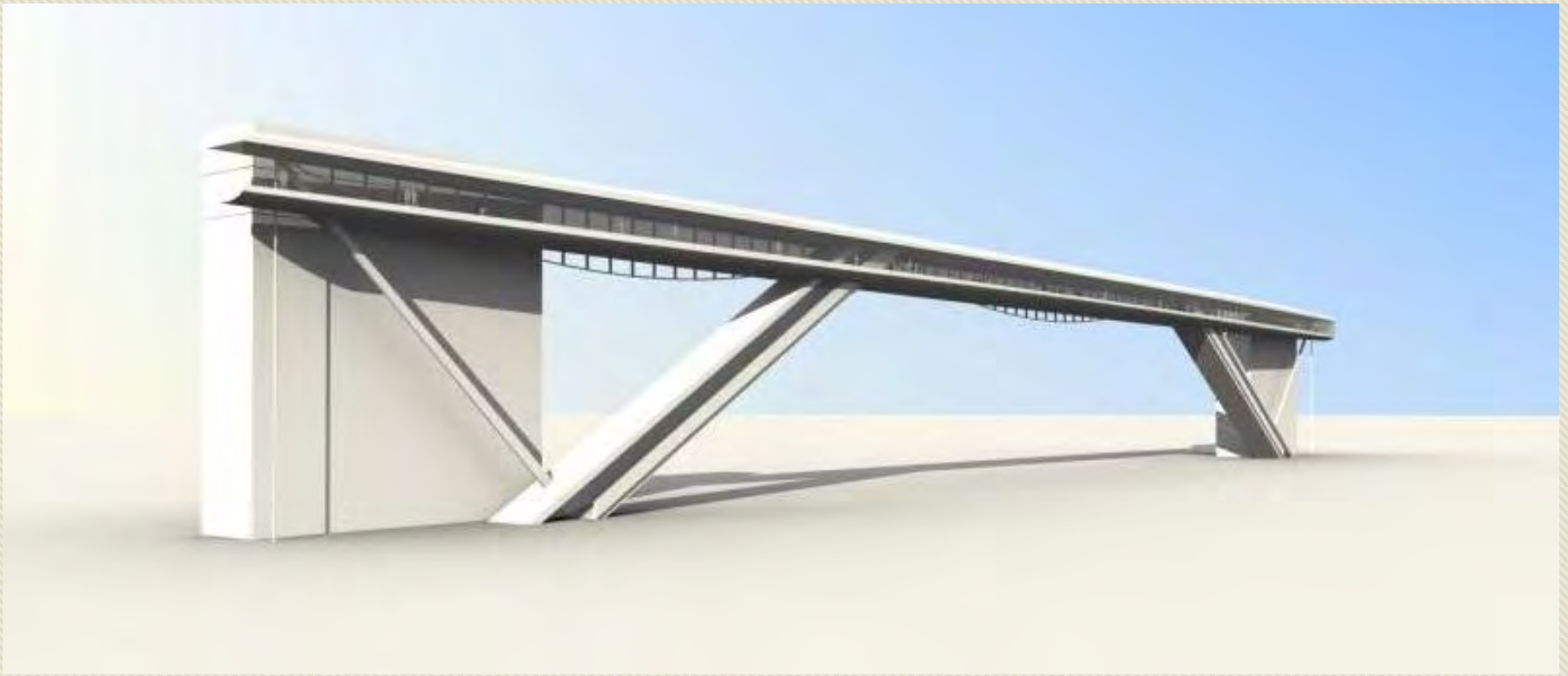

Early Schematic Design of Passenger Bridge

Target Schedule - Accepted

Complete Schematic Design (30%)	April 2016
Begin Subcontractor Procurement	May 2016
Commence Preliminary Construction	July 2016
Complete Design Development (60%)	September 2016
Negotiate Guaranteed Maximum Price	November 2016
Design Level - 90%	May 2017
Complete Design – 100%	September 2017
Complete Construction	3Q19
IAF Open to International Travelers	4Q19

Design-Builder's Target Schedule Based on Validation Concept

Target Budget – Under Negotiation

Design-Builder Submits Target Budget Based on Validation Concept

Contract Execution Timetable

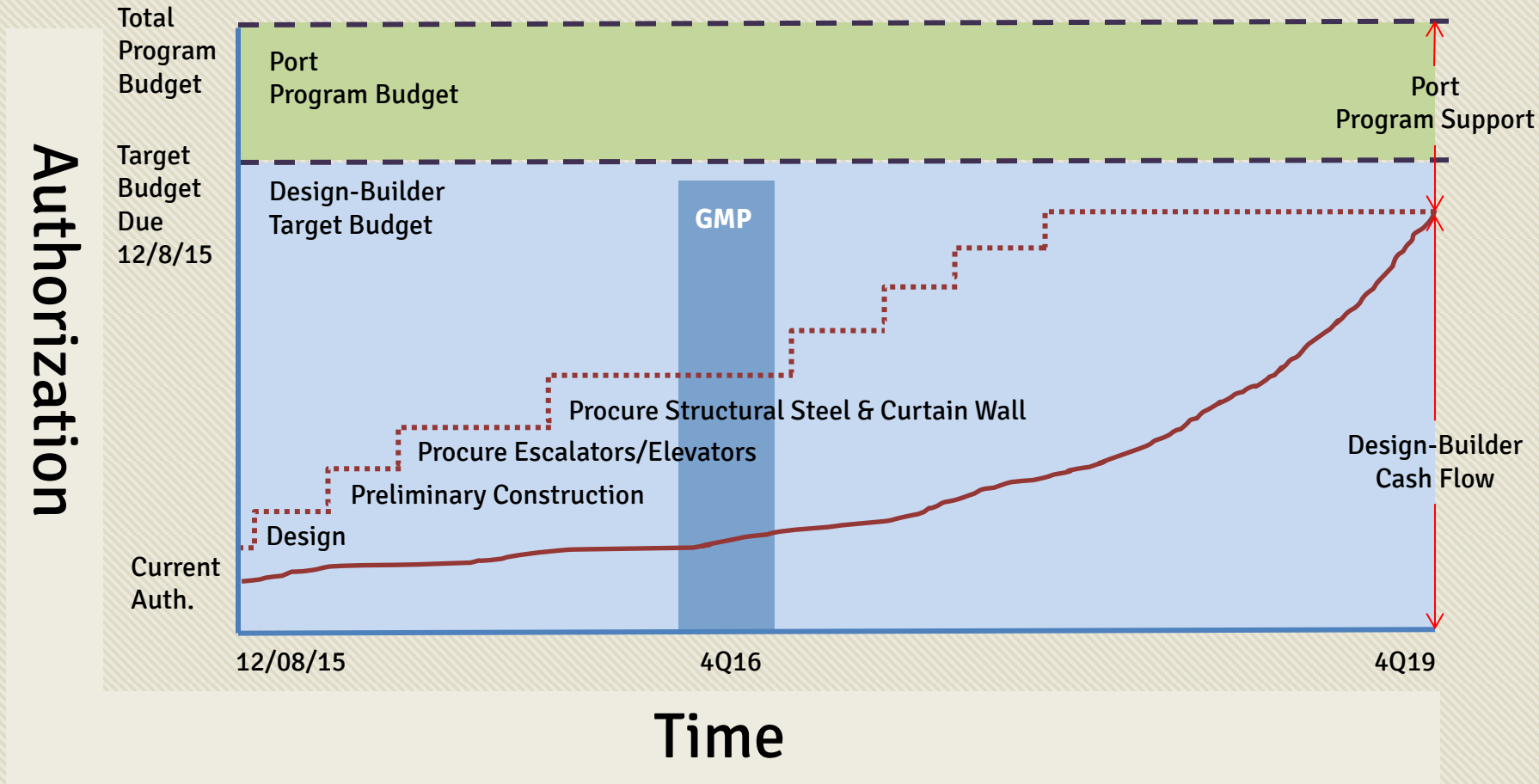

- Contractual Commitments
- Cash Expenditure to Meet Commitments and Build Project

Contract Execution Timetable Recommended to Take Full Advantage of Progressive Design Build

GMP Development Period Work Scope

- Design & General Conditions
- Preliminary Construction
 - Sitework/Demolition
 - Utilities Relocation
 - Foundations/Concrete/Rebar
 - Enabling Projects
- Procurement of Long Lead Items
 - Structural Steel
 - Glass/Metal Panel Curtain Wall System
 - Elevator , Escalator & Moving Walkways
 - BHS
 - Pre-construction & Major Equipment Purchase for Primary Sub-Contracts (Mechanical, Electrical, Low-Voltage)
- WA State Tax
- Program Support

Requested Authorization Will Advance the Project and Address GMP Development Period Work Scope

Additional Funds Requested for the GMP Development Period of the Contract (December 2015 to 1Q17)

- Design Fees \$ 12 Million
- Contractor Fees \$ 21.5 Million
- Program Support \$ 12 Million
- Preliminary Construction \$230 Million
- **Total New Funding** **\$275.5 Million**
- Prior Approvals \$ 24.5 Million
- Total \$300 Million

Authorization for Funding and Approval to Commence GMP Development
Period

Thank you



Target Budget – Under Negotiation

Reporting Format Using Preliminary Projected Costs -
Design-Builder Will Submit Target Budget Based on Validation Concept

Additional Funds Requested for the GMP Development Period of the Contract (December 2015 to 1Q17)

- Design Fees \$ 12 Million
- Contractor Fees \$ 21.5 Million
- Program Support \$ 12 Million
- **Total New Funding \$ 45.5 Million**
- Prior Approvals \$ 24.5 Million
- Total \$ 115.5 Million

Authorization for Funding and Approval to Commence GMP Development
Period